

# Always on the top!

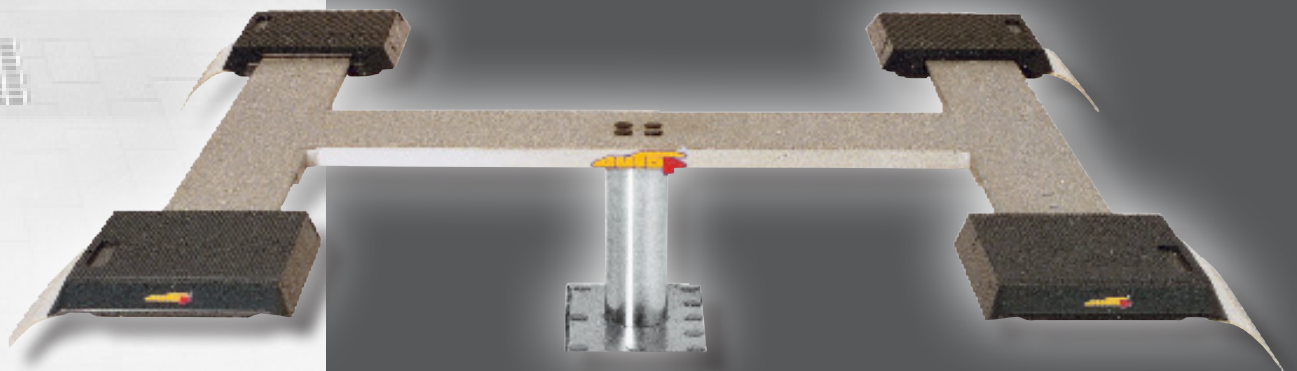

## autop Sololift 1.35 Pv 120-180, 140-200, 160-220

This platform has a very low drive-over height and a sturdy construction. Due to its comfortable length adjustment you can reach nearly every lifting point of a private car.

Handy rubber blocs are used for a correct lifting at the recommended lifting points.

The non-sliding surface of the superstructure together with the rubber blocs assure a safe lifting.



### autop Maschinenbau GmbH

Sandkampstr. 90

D-48432 Rheine

Tel. ++49(0)5971/8602-02

Fax ++49(0)5971/8602-25

E-Mail: [mail@autop.de](mailto:mail@autop.de)

[www.autop.de](http://www.autop.de)

...a company of the STENHØJ-group!

  
Professional lifting technology!

# Sololift 1.35

## Components

- hard-chromed cylinder
- corrosion-free guiding element
- SPS - control unit
- pneumatic emergency drain
- installation in waterproof cassette
- use of „bio-oil“ non hazardous to water
- platform, extendable from 1200-2000 mm, sturdy welded and galvanized
- **Optional extra:**  
xy-heads for the increase of the lifting area

## Colour:

zinc-coated and painted in RAL 9006

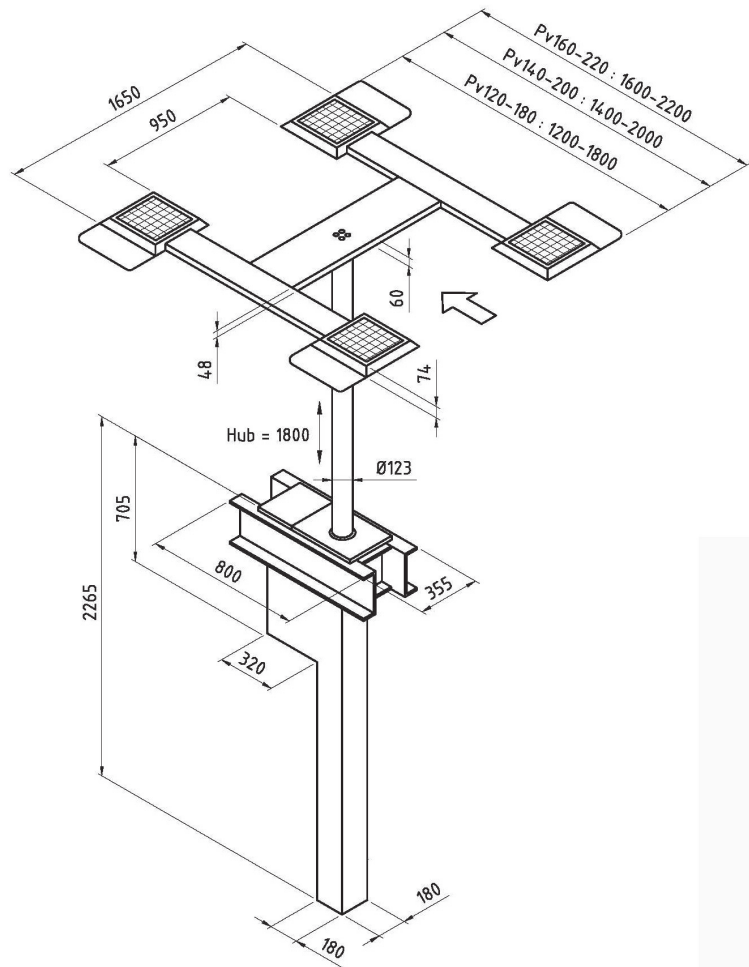

## Technical data

Capacity:	3,500	kg
Cylinder's diameter:	123	mm
Lifting/lowering time:	appr. 30	sec.
Stroke length:	1,800	mm
Lifting height:	1,930	mm
Foundation depth:	2,400	mm
Voltage:	230/400	V
	50	Hz
	16	A
Power unit:	3.0	kW



No liability accepted for specifications that are subject to alteration - validity 03.2012. The date and pictures in this product information are not binding and are only giving an approximate description. Moreover we reserve the right of differences between the goods delivered and the date and pictures given here (i.e. technical data, equipment, material and optical appearance) so far as the differences are reasonable for the customer and a possible reduction in value of the goods delivered is not considerable.

## autop Maschinenbau GmbH

Sandkampstr. 90

D-48432 Rheine

Tel. ++49(0)5971/8602-02

Fax ++49(0)5971/8602-25

E-Mail: mail@autop.de

www.autop.de

...a company of the STENHØJ-group!

## Service:

Our expert consultants would appreciate to help you with the planning of a new garage or the modernization of an existing one. We offer to work out a workshop concept incl. an equipment proposal.

**Please do not hesitate to contact us!**

