

Always on the top!



autop Sololift 1.30 Fv Uni

The autop Sololift 1.30 Fv Uni is especially suitable for washing, general maintenance and reconditioning of used cars.

Easy access and lifting. The Sololift Fv Uni is a very flexible lift; the lifting area can e.g. be modified to suit vehicles with long wheel bases, by either re-positioning the adaptors, or alternatively fitting more adaptors.

With a minimum height of only 80 mm the Sololift Fv Uni is suitable for also very low vehicles.

The lift is hot galvanized so as to ensure long life and reliable operation.

autop Maschinenbau GmbH

Sandkampstr. 90

D-48432 Rheine

Tel. ++49(0)5971/8602-02

Fax ++49(0)5971/8602-25

E-Mail: mail@autop.de

www.autop.de

...a company of the STENHØJ-group!

Professional lifting technology!

Sololift 1.30 Fv Uni

Components

- hard-chromed cylinder
- corrosion-free guiding element
- SPS - control unit
- pneumatic emergency drain
- installation in waterproof cassette
- use of „bio-oil“ non hazardous to water
- on-floor superstructure with hot galvanized sturdy welded rails

Standard:

hot-galvanized

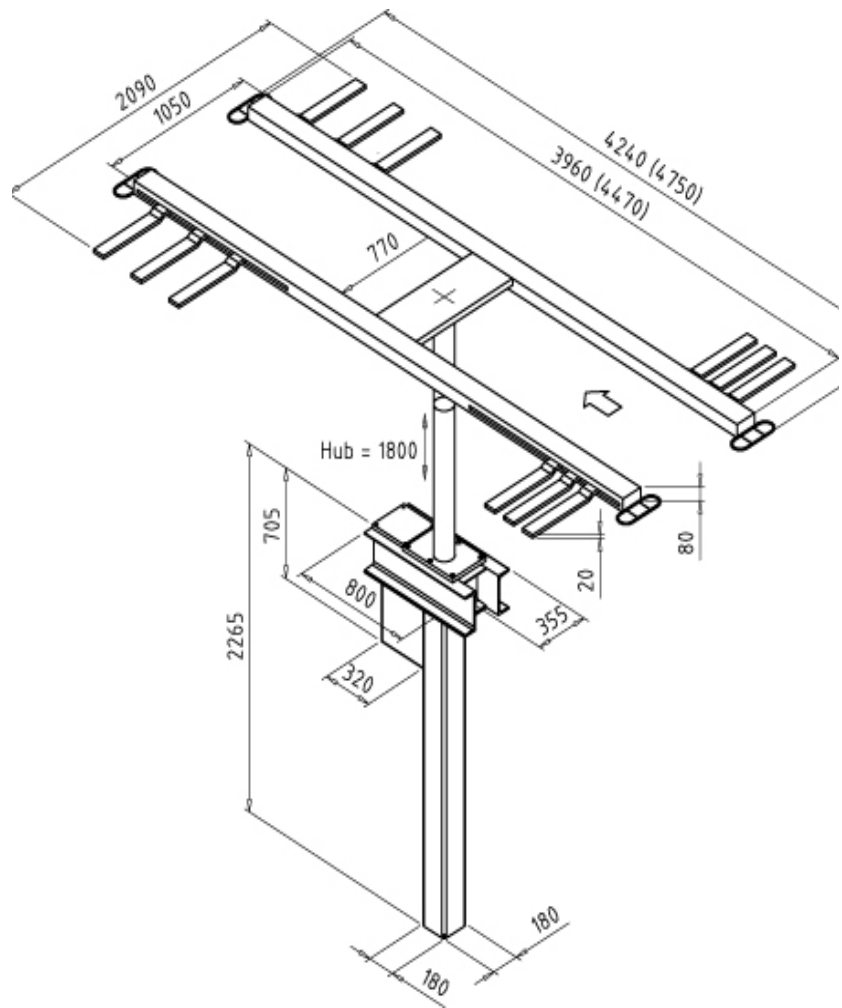

Technical data:

Capacity:	3,000	kg
Cylinder's diameter:	123	mm
Lifting/lowering time:	appr. 30	sec.
Stroke length:	1,800	mm
Lifting height:	1,820	mm
Foundation depth:	2,400	mm
Voltage:	230/400	V
	50	Hz
	16	A
Power unit:	3.0	kW

Superstructure

Length, short version:	4,240	mm
Length, long version:	4,750	mm
Width:	1,050/2,090	mm
Height:	20/80	mm
Wheel base		
short version:	1,800-3,400	mm
long version:	1,800-3,900	mm

Service:

Our expert consultants would appreciate to help you with the planning of a new garage or the modernization of an existing one. We offer to work out a workshop concept incl. an equipment proposal.

Please do not hesitate to contact us!



No liability accepted for specifications that are subject to alteration - validity 07/2011. The date and pictures in this product information are not binding and are only giving an approximate description. Moreover we reserve the right of differences between the goods delivered and the date and pictures given here (i.e. technical data, equipment, material and optical appearance) so far as the differences are reasonable for the customer and a possible reduction in value of the goods delivered is not considerable.

autop Maschinenbau GmbH

Sandkampstr. 90

D-48432 Rheine

Tel. ++49(0)5971/8602-02

Fax ++49(0)5971/8602-25

E-Mail: mail@autop.de

www.autop.de

...a company of the STENHØJ-group!

