

The hardware for your bodyshop!

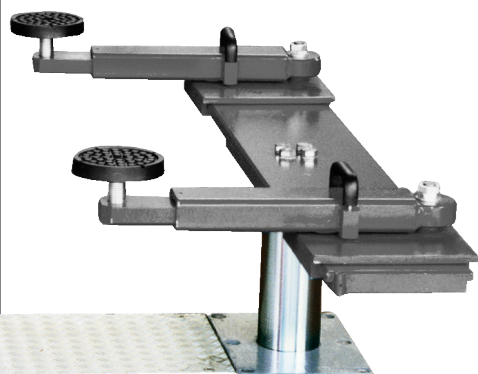
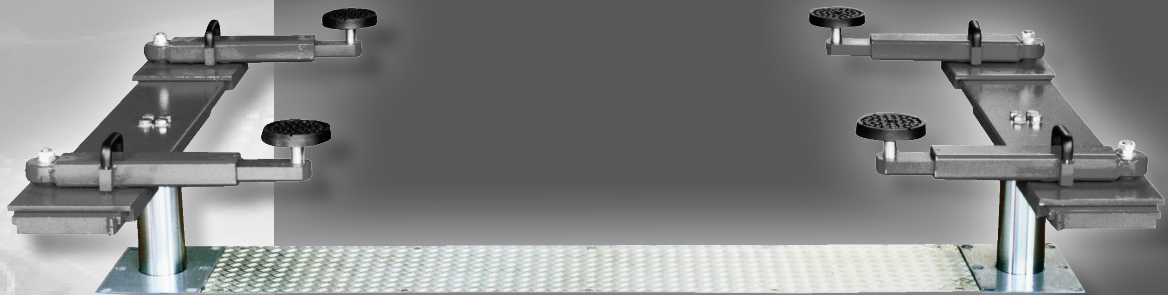

autop Masterlift 2.30 Sav 230

This lift allows a comfortable repair of damaged vehicles with a straightening bench. The requirements for a body repair lift are:

- free access to all sides of the vehicle
- drive-in with a straightening bench without obstacle
- flexible and variable swivel arms
- comfortable lifting of the vehicle even with a straightening bench
- security arm locking system

Very flexible lift for body repair.

autop Maschinenbau GmbH

Sandkampstr. 90

D-48432 Rheine

Tel. ++49(0)5971/8602-02

Fax ++49(0)5971/8602-25

E-Mail: mail@autop.de

www.autop.de

...a company of the STENHØJ-group!

autop[®]
Professional lifting technology!

Masterlift 2.30 Sav 230

Components

- two hard-chromed hydraulic cylinders
- corrosion-free guiding elements
- SPS - control unit
- pneumatic emergency drain
- flexible synchronizing and safety device
- installation in waterproof cassette
- use of „bio-oil“, non hazardous to water
- two on-floor platforms with four telescopic swivel arms on traverses, in length adjustable, incl. four screw pads Ø 120 mm and height adjustable 125-175 mm

Standard colour:

RAL 7016 (grey anthracite)

on request

RAL 5019 (blue)

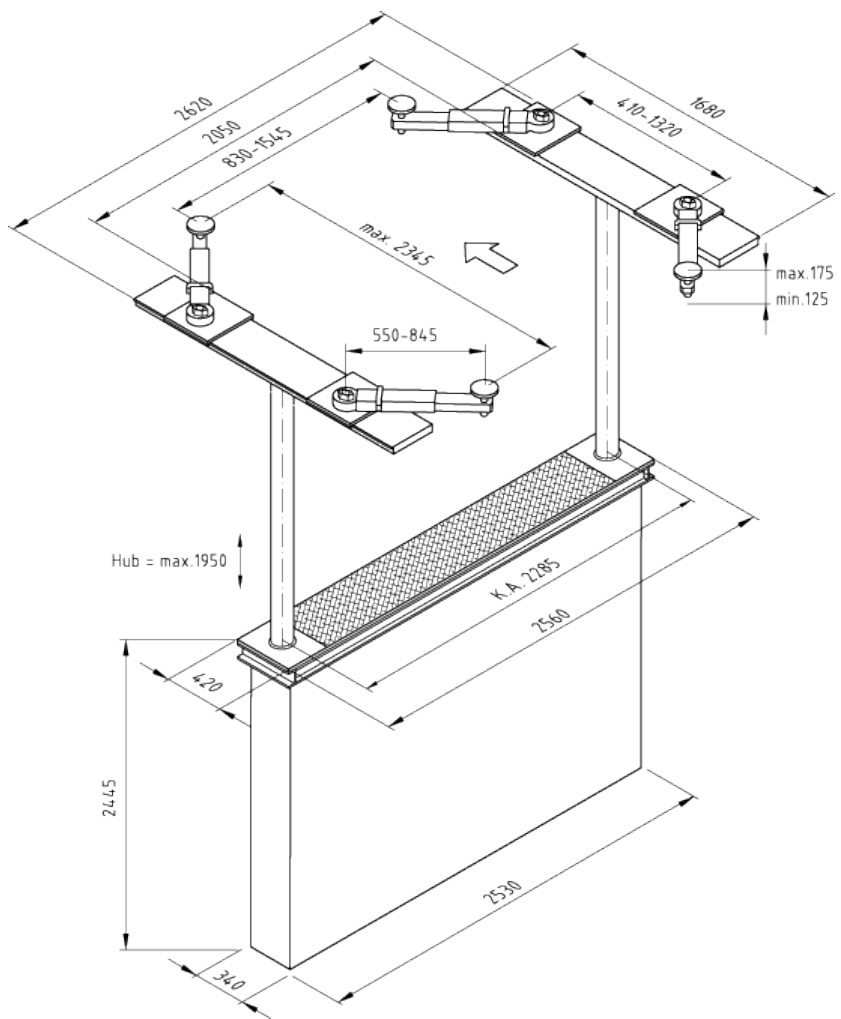

Technical data:

Capacity:	3,000	kg
Piston distance:	2,285	mm
Cylinders' diameter:	2 x 123	mm
Lifting/lowering time:	appr. 30	sec.
Stroke length:	1,950	mm
Lifting height, dep. on lifting pads:	2,075-2,125	mm
Foundation depth:	2,615	mm
Voltage:	230/400	V
	50	Hz
	16	A
Power unit:	3.0	kW



No liability accepted for specifications that are subject to alteration - validity 07/2011. The date and pictures in this product information are not binding and are only giving an approximate description. Moreover we reserve the right of differences between the goods delivered and the date and pictures given here (i.e. technical data, equipment, material and optical appearance) so far as the differences are reasonable for the customer and a possible reduction in value of the goods delivered is not considerable.

autop Maschinenbau GmbH

Sandkampstr. 90

D-48432 Rheine

Tel. ++49(0)5971/8602-02

Fax ++49(0)5971/8602-25

E-Mail: mail@autop.de

www.autop.de

...a company of the STENHØJ-group!

Service:

Our expert consultants would appreciate to help you with the planning of a new garage or the modernization of an existing one. We offer to work out a workshop concept incl. an equipment proposal.

Please do not hesitate to contact us!

autop[®]
Professional lifting technology