

The hardware for your workshop!

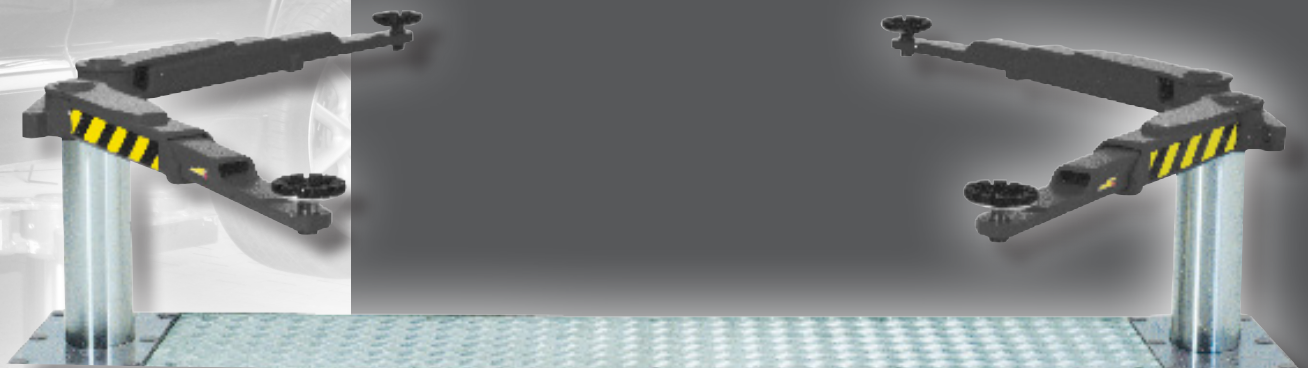

autop Masterlift 2.30 Sa 230

This swivel arm autop Masterlift Sa sport with piston distance 2.285 mm is used for repair and maintenance as well as for body repair.

The extremely low drive-over height of 70 mm corresponds to the latest developments of sport cars.



autop Maschinenbau GmbH

Sandkampstr. 90

D-48432 Rheine

Tel. ++49(0)5971/8602-02

Fax ++49(0)5971/8602-25

E-Mail: mail@autop.de

www.autop.de

...a company of the STENHØJ-group!

autop[®]
Professional lifting technology!

Masterlift 2.30 Sa 230

Components

- two hard-chromed hydraulic cylinders
- corrosion-free guiding elements
- SPS - control unit
- pneumatic emergency drain
- flexible synchronizing and safety device
- installation in waterproof cassette
- use of „bio-oil“, non hazardous to water
- Two on-floor swivel arm bridges with telescopic arms and height adjustable lifting pads as well as integrated automatic arm unlocking system

Standard colour:

RAL 7016 (grey anthracite)

on request

RAL 5019 (blue)

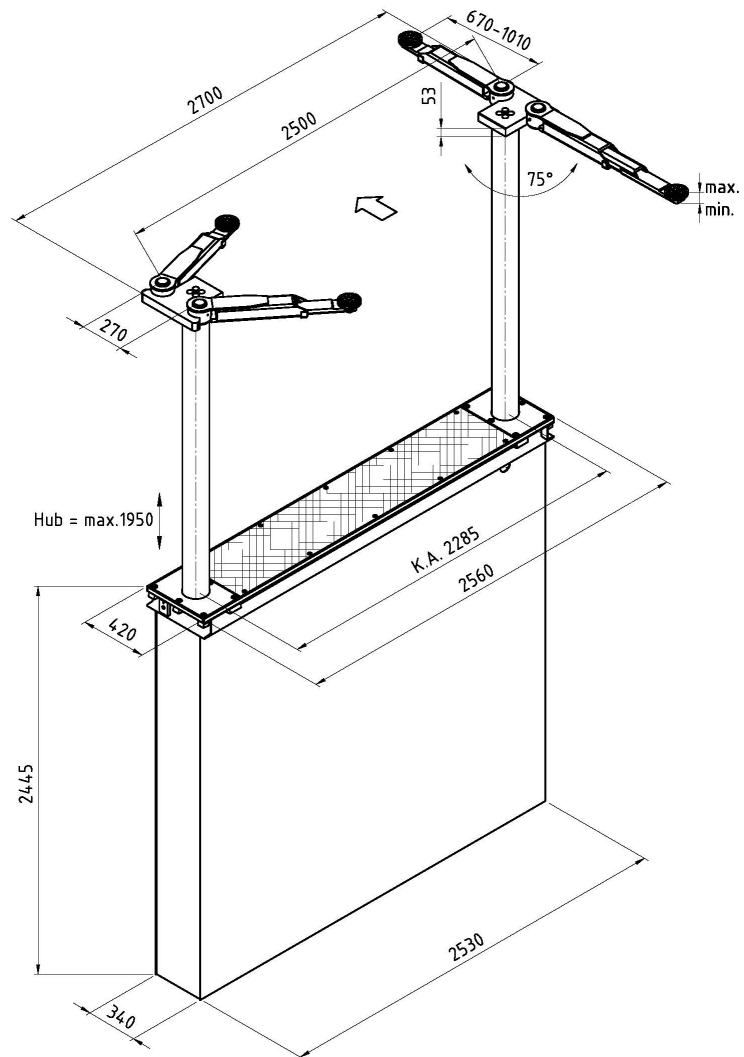

Technical data:

Capacity:	3,000	kg
Piston distance:	2,285	mm
Cylinders' diameter:	2 x 123	mm
Lifting/lowering time:	appr. 30	sec.
Stroke length:	1,950	mm
Lifting height:	2,020-2,370	mm
Foundation depth:	2,615	mm
Voltage:	230/400	V
	50	Hz
	16	A
Power unit:	3.0	kW



No liability accepted for specifications that are subject to alteration - validity 07/2011. The data and pictures in this product information are not binding and are only giving an approximate description. Moreover we reserve the right to change the design, construction, material and technical data without notice. The technical data equipment for material and applied appearance is for the customer and is possible reduction in value of the goods delivered is not considered.

autop Maschinenbau GmbH

Sandkampstr. 90

D-48432 Rheine

Tel. ++49(0)5971/8602-02

Fax ++49(0)5971/8602-25

E-Mail: mail@autop.de

www.autop.de

...a company of the STENHØJ-group!

Service:

Our expert consultants would appreciate to help you with the planning of a new garage or the modernization of an existing one. We offer to work out a workshop concept incl. an equipment proposal.

Please do not hesitate to contact us!

autop[®]
Professional lifting technology